



Deep Sea Electronics Plc

500 Series CONTROL MODULES

MODEL 512 MANUAL START MODULE

DESCRIPTION

The Model 512 is an **Manual Engine Control Module**, which has been designed to allow the OEM to meet most of the industry's complex specifications. The module is used to start and stop the engine, indicating the operational status and fault conditions; automatically shutting down the engine and indicating the engine failure by a flashing LED and other simultaneous faults by a steady LED on the front panel. Selected operational sequences, timers and alarms can be altered by the customer. Alterations to the system are made by using either the 807 hand held calibration unit or a PC and the 808 interface. This also provides the operator with real time diagnostic facilities to monitor the operation of the system.

Operation of the module is via a two position key switch mounted on the front panel with STOP and RUN positions. A START pushbutton is fitted to facilitate engine cranking.

Microprocessor control allows **enhanced manual start operation**, Crank inhibit if the engine is running, automatic crank disconnect and also a crank limit timer to prevent starter motor damage in the event of a fail to start occurring.

Relay outputs are provided for Fuel Solenoid Output, Start Output and two configurable outputs. Normally the relays are configured as pre-heat and alarm output. However the relay function is configurable to activate on a range of functions, conditions or alarms. The relays supply positive plant supply out.

Configurable inputs are available for Low Oil Pressure, High Engine Temperature and Remote Fuel On. This allows the module to function with N/O or N/C switches. Two fully configurable auxiliary inputs are provided to give protection expansion. These can be selected to be indication, warning or shutdown inputs either immediate or held off during start up. Uncommitted LED's allow annunciation.

Multiple alarm channels are provided to monitor the following:- Overspeed, Charge Fail, Emergency Stop, Low oil pressure, High engine temperature, and programmable inputs as selected. First up alarm is indicated by a flashing LED. Subsequent alarms are displayed by a steady LED.

The **Remote Fuel On** facility is intended for use where a dual engine start position is required. The module will turn on the fuel supply and provide all normal protections to the engine. However engine cranking must be

SPECIFICATION



DC Supply:

8 to 35 V Continuous.

Cranking Dropouts:

Able to survive 0 V for 50 mS, providing supply was at least 10 V before dropout and supply recovers to 5V. *This is achieved without the need for internal batteries.*

Max. Operating Current:

150 mA at 12 V. 180 mA at 24 V.

Max. Standby Current:

15 mA at 12 V. 21 mA at 24 V. (In stop position consumption is zero.)

Alternator Input Range:

15 - 300 V ac RMS

Alternator Input Frequency:

50 - 60 Hz at rated engine speed.

Magnetic Input Range:

0.5 V to +/- 70 V (Clamped by transient suppressors)

Magnetic Input Frequency: 10Hz to 10,000 Hz at rated engine speed.

Start Relay Output:

16 Amp DC at supply voltage.

Fuel Relay Output:

16 Amp DC at supply voltage.

Pre-heat/Auxiliary Relay Outputs:

5 Amp DC at supply voltage.

Dimensions:

96 X 96 X 140.5 (Excluding Key-switch)

Charge Fail / Excitation Range:

0 V to 35 V

Operating Temperature Range:

-15 to +55°C

CASE DIMENSIONS

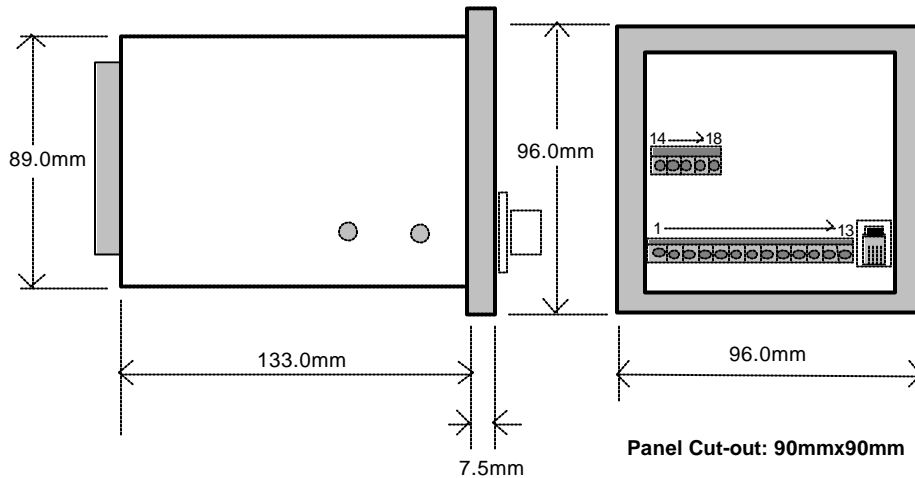

TYPICAL CONNECTIONS

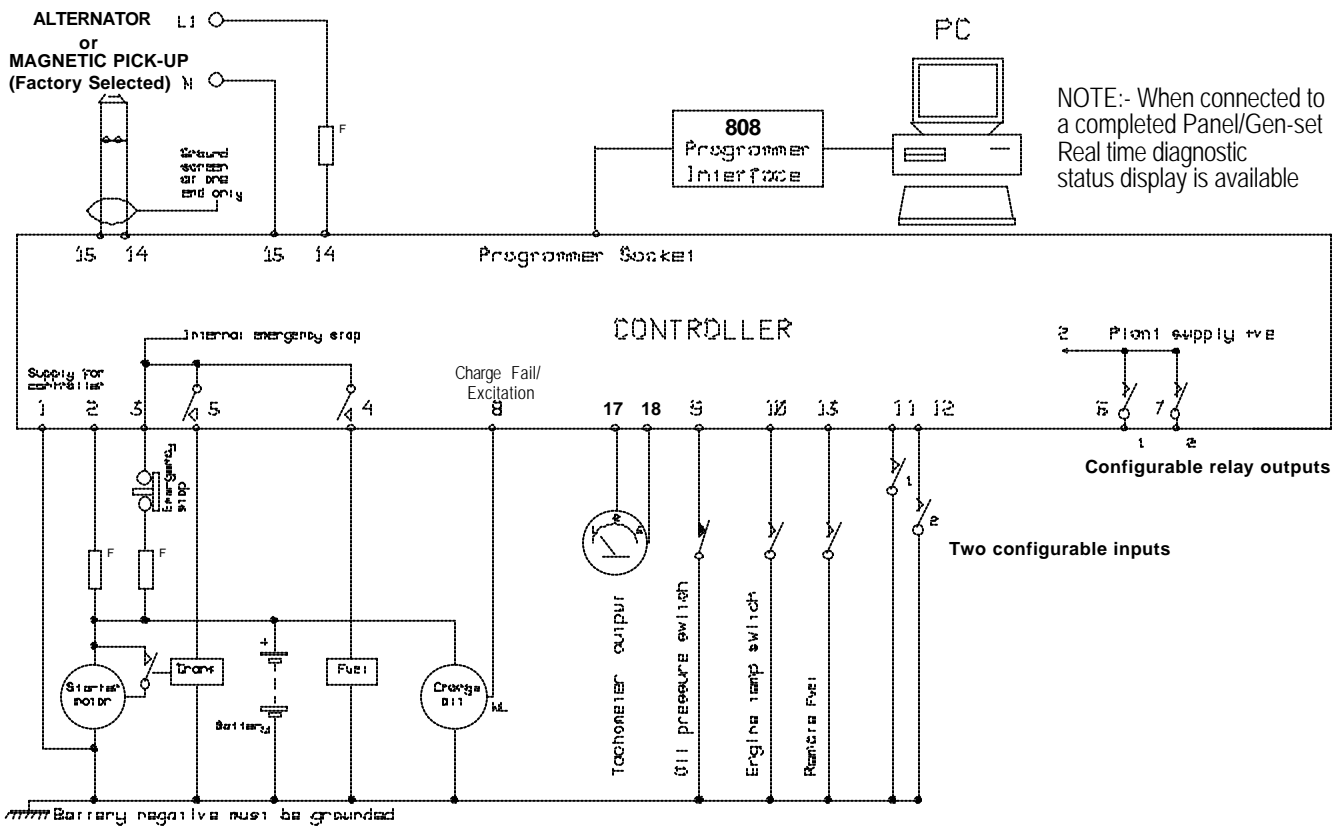

Deep Sea Electronics Plc

Mountside Park, Queen Margarets Road,
Scarborough, YO11 2RH. ENGLAND

Tel:- +44 (0)1723 377566 Fax:- +44 (0)1723 354453 E-Mail:- sales@deepseapl.com