



DESCRIPTION

The Model 501NK is an Engine Protection Module, designed to control the engine via an externally fitted switch provided by the OEM. The module is used to protect the engine and indicate fault conditions, automatically shutting down the engine and indicating the engine failure by LED, giving true first up fault annunciation.

Operation of the module is via a terminal providing a 'RUN' input, which also powers the module. The OEM must provide suitable arrangements for starter operation externally, such as a push-button or keyswitch position. If the 'Run' input is de-energised the DC supply is removed from the module and the run relay and alarm output are de-energised. If the 'Run' input is energised, the module is powered up and the run relay is energised, activating the engine fuel/ignition system and the protection hold-off timer is initiated. The external starter circuit should then be operated. Once the engine is running the external starter circuit should be de-energised.

Operation of any of the following alarms; **Low Oil Pressure, High Engine Temperature, Auxiliary Shutdown, Overspeed (Optional)**, will cause the run relay to de-energise. This will remove the fuel/ignition supply from the engine and bring it to rest. The Alarm Output will be activated giving a positive DC output. Each alarm channel has its own LED indicator and once activated, no further alarm conditions will be accepted. The alarm output and relevant LED will remain active until the unit is reset by de-energising the 'Run' input.

Overspeed Protection (Optional) is achieved by an additional factory-fitted PCB in the module. This provides integral overspeed protection derived from either the generator HZ output or the engine magnetic pick-up (*specified on ordering*). The overspeed circuit continuously monitors the engine speed and will shut down the engine immediately if a pre-set speed level is exceeded. This trip level is adjustable from 90% to 130% of full rated speed and is suitable of both 50Hz or 60Hz systems.

During engine cranking, and for a short time afterwards, the **protection hold-off timer** is active and the relevant alarm inputs are inhibited. This enables the engine to start and achieve normal running conditions. Once the timer has expired the inputs are enabled and the module returns to providing normal protection.

Charge Failure warning is also provided by monitoring the WL terminal on the charge alternator. This operates on a similar principal to the warning lamp fitted in a motor vehicle; should the output fail the charge fail LED will illuminate. The module will also provide the alternator excitation current via this connection.



SPECIFICATION

DC Supply:

9 to 33 V Continuous.

Cranking Dropouts:Able to survive voltage dips during cranking. *This is achieved without the need for internal batteries.***Alternator Input Range:**

15 - 305 V AC RMS

Alternator Input Frequency:

50 - 60 Hz at rated engine speed.

Magnetic Input Range:

0.5 V to +/- 80 V

Magnetic Input**Frequency:** 2300Hz to 6000 Hz at rated engine speed.**Run Relay Output:**

16 Amp DC at supply voltage.

Alarm Output:

1 Amp DC at supply voltage.

Dimensions:

72 X 72 X 118.5 mm

Operating Temperature Range:

-30 to +70°C

Installation:

Front panel mounting via suitable cut-out. Retaining clips supplied. Cable connections via locking plug and socket type connectors.

Calibration:

Speed trip setting and meter calibration adjustment potentiometer are accessible from the rear of the module.

CASE DIMENSIONS

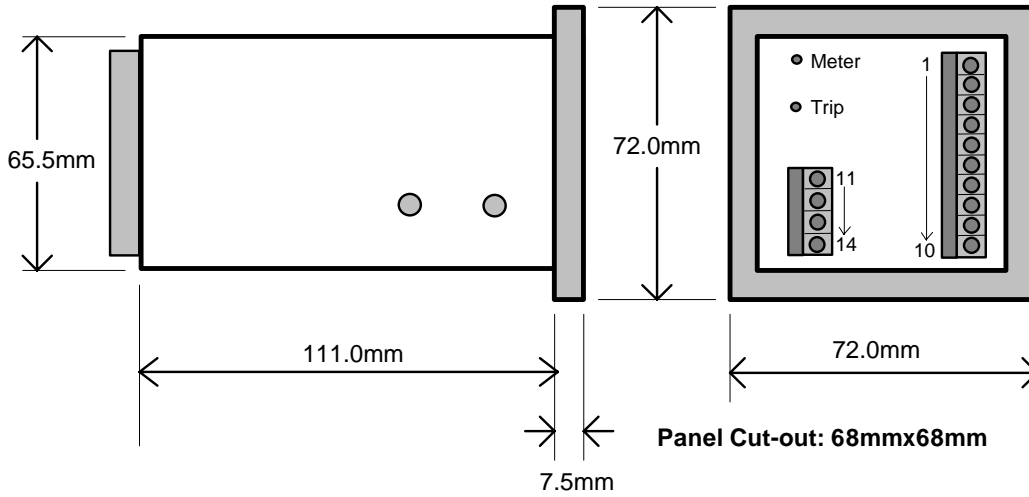

TYPICAL CONNECTIONS

Please note that the following are typical wiring diagrams only

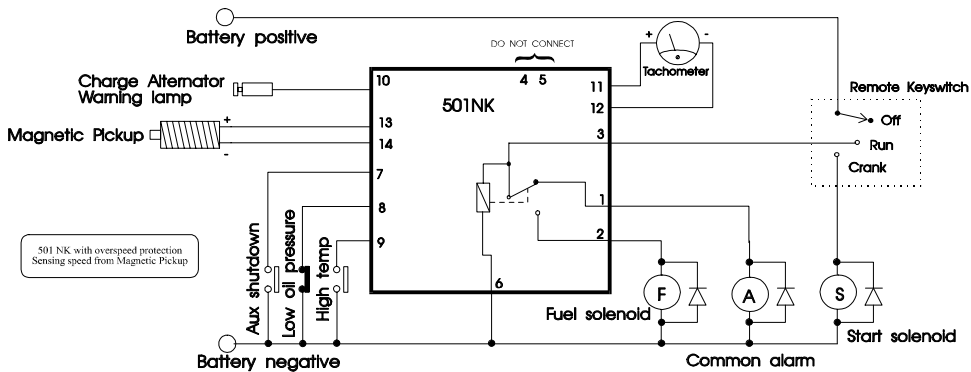
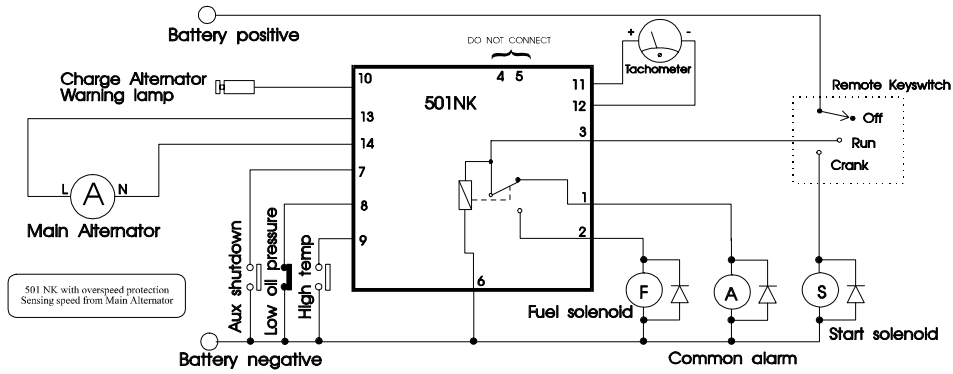
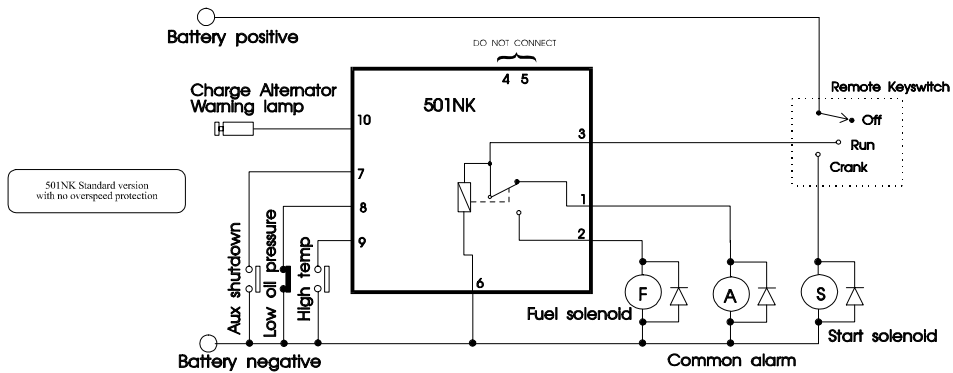

Deep Sea Electronics plc

Highfield House, Hunmanby Industrial Estate, North Yorkshire, YO14 0PH, England
 Tel: +44 (0) 1723 890099 Fax: +44 (0) 1723 893303 E-mail sales@deepseapl.com