

721 Digital Speed Control for Power Generation Applications



APPLICATIONS

The 721 Digital Speed Control is a powerful, configurable load sharing and speed control with a torsional filter. The 721 control governs gas or diesel reciprocating engines driving generators through flexible couplings. Using inputs from both the engine and generator sides of the coupling, the 721 control filters out torsionals in the speed signals. As a result, transient performance is improved without sacrificing steady-state stability.

The 721 Digital Control can share load between multiple engines driving a common mechanical or electrical load. It offers automatic bumpless transfer of load between engines and adjustable load and unload ramp rates. The control also provides a limiter to prevent engine overfueling or flooding during start-up.

CONTROL DYNAMICS

The 721 Digital Control uses a 16-bit microprocessor, providing control dynamics that give smooth steady-state operation and fast response to speed and load changes. The 721 Digital Control dynamics are varied automatically as functions of both speed and load to provide better performance over the operating range of the engine. Two separate sets of dynamic adjustments are externally selectable, for circumstances where operating conditions change.

The Woodward Hand Held Programmer makes all adjustments quickly and easily through the control's ten convenient "menus" (a standard ASCII character computer terminal with an RS-422 serial port may also be used). The control saves all set points in permanent memory, which

- Torsional Filter for Flexible Engine/Generator Coupling Torsionals
- Torsional Detector Can Alarm or Derate Engine on Detection of Abnormal Torsionals
- Integral Load Sharing With Soft Load/Unload Ramps and Automatic Breaker Opening
- Remote Speed and Load Setting
- User Configurable for a Wide Range of Applications
- 5 Slope Turbo-Boost Limiter
- EU Directive Compliant; UL/cUL Listed

does not require batteries or other power sources to retain data. The Handheld Programmer prevents tampering with set points, yet allows entries to be changed at any time.

Menu 1 (Dynamics Setpoints) — adjusts the control to match the stability and transient performance of the engine.

Menu 2 (Auxiliary Dynamics) — same as Menu 1; sets a second set of (auxiliary) dynamics.

Menu 3 (Speed Setting) — sets adjustments related to speed control (speed limits, ramp times and rates, remote speed reference, tachometer, droop).

Menu 4 (Torsional Filter) — adjusts the control to recognize flexible coupling torsionals.

Menu 5 (KW Load Setting) — sets adjustments related to load control (load input range, load ramp times and rates, remote KW reference, load droop).

Menu 6 (Fuel Limiters) — sets fuel limit adjustments that limit and define actuator output current (idle fuel limit, maximum fuel limit, etc.).

Menu 7 (Display 1) — Displays current values for engine speed, speed reference, generator load, load reference, actuator output, torsional level, speed control mode, load control mode.

Menu 8 (Configuration) — Sets control configuration (rated speed, gear teeth, actuator sense, dynamics map, alarms).

Menu 9 (Calibration) — Sets control calibration (key inputs and outputs).

Menu 0 (Display 2) — Displays current values for analog and digital speed inputs, contact status of all contacts, relay status for all relays, and other control functions.

BLOCK DIAGRAM

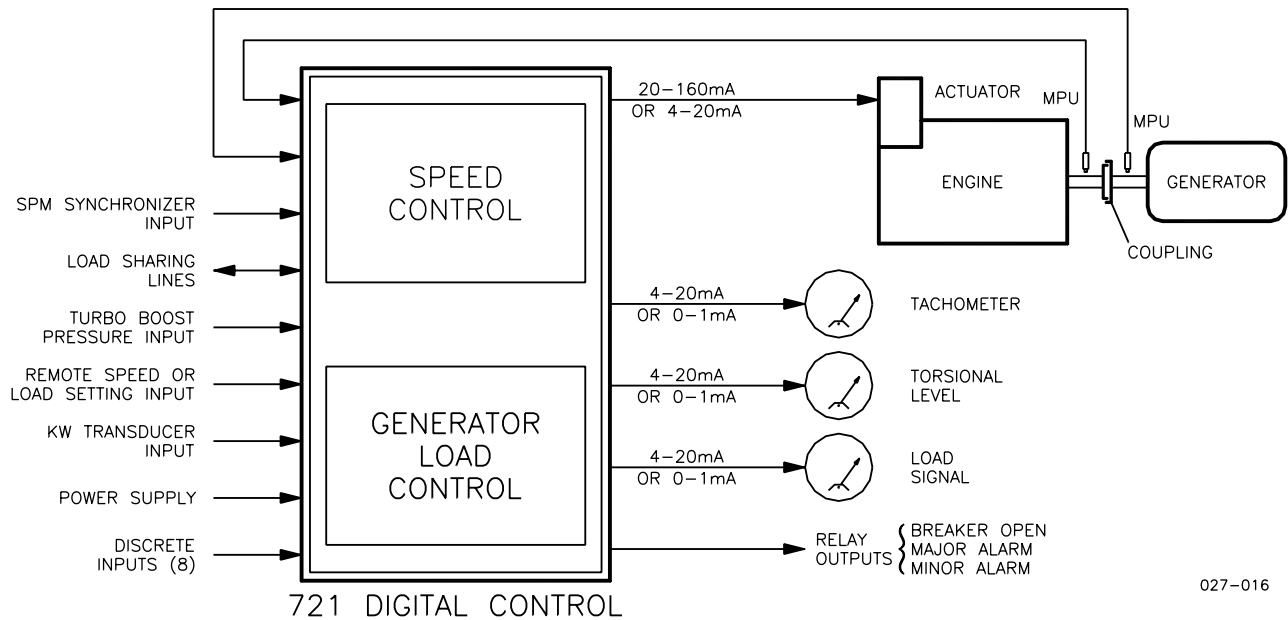

SPECIFICATIONS

ENVIRONMENTAL SPECIFICATIONS

| | |
|-----------------------------|---|
| Operating Temperature | -40 to +70 °C (-40 to +158 °F) |
| Storage Temperature | -55 to +105 °C (-67 to +221 °F) |
| Humidity | 95% at 38 °C (100 °F) US MIL-STD 810D, Method 507.2, Proc. III |
| EMI/RFI Specification | EN 50082-2 and EN 50081-2 |
| Salt Spray | ASTM B 117-73 |
| Mechanical Vibration..... | 24–2000 Hz swept sine, 2.5Gs constant accel. |
| Mechanical Shock..... | US MIL-STD 810C, Method 516.2, Proc. I, II, V |

CONTROL CHARACTERISTICS

| | |
|-------------------------------|---|
| Steady State Speed Band | Rated speed $\pm 1/4$ of 1% over all operating conditions |
|-------------------------------|---|

INPUTS

| | |
|------------------------------------|--|
| Speed Signal input and Range | 1–2 magnetic pickups or 1–2 prox. switches 400 Hz to 15 000 Hz (8–2100 rpm) |
| Power Supply | 18–40 Vdc (24 or 32 Vdc nominal)88–132 Vac 50/60 Hz (120 Vac nominal)90–150 Vdc (125 Vdc nominal) |
| Power Consumption | 18 W nominal |
| Discrete Inputs | On/Off (control) Run/Stop Idle/Rated Raise/Lower Speed Failsafe Override Unload/Reset to Rated Isochronous Base Loading Isochronous/Droop |

LOAD SHARING LINES INPUT

| | |
|---------------------------------------|--|
| Remote Speed/Load Setting Input | 4–20 mA or 1–5 Vdc for remotely setting engine speed/load |
| Turbo Boost Pressure Input | 4–20 mA or 1–5 Vdc from turbo boost pressure sensor, for smoke limiting and to prevent overfueling during transients |
| SPM Synchronizer Input..... | ± 5 Vdc input from speed and phase matching (SPM) synchronizer |
| KW Transducer Input | 4–20 mA or 1–5 Vdc from kW transducer |

OUTPUTS

| | |
|-------------------------------------|--|
| Actuator | 20–160 mA or 4–20 mA |
| Tachometer Output | 4–20 mA or 0–1 mA for analog meter or as input to another computer |
| Torsional Level Signal Output | Same as tachometer output |
| Load Signal Output | Same as tachometer output |
| Relays | Breaker Open, Major Alarm, Minor Alarm |

COMPLIANCE

| | |
|---|---|
| UL/cUL | Listed |
| European Union (EU)..... | Compliant with EMC Directive 89/336/EEC (some models) |
| American Bureau of Shipping (ABS) | Registered |

3800 N. Wilson Ave.
 P.O. Box 3800
 Loveland, CO, U.S.A.
 80539-3800
 Ph: 1 970-663-3900
 Ph: 1 800-835-5182
 Fax: 1 970-962-7050

www.woodward.com



International Plants
 Australia, New South Wales
 Brazil, Campinas
 China, Tianjin
 Germany, Aken/Elbe & Kelbra
 India, Haryana
 Japan, Tomisato & Kobe
 Netherlands, Hoofddorp & Rotterdam
 Singapore
 United Kingdom, Reading, England, & Prestwick, Scotland
 United States, Colorado[2], Illinois[3], Michigan[2], New York, South Carolina, Tennessee

Regional Sales Offices
 Canada, Québec
 China, Beijing
 Czech Republic, Plzen
 Germany, Tettnang
 Korea, Pusan
 Mexico, Mexico City
 New Zealand, Christchurch
 Poland, Warsaw
 United Arab Emirates, Abu Dhabi
 United States, Alabama, California, Illinois, Pennsylvania, Texas, Washington

Distributors & Service
 Woodward has a network of distributors and service facilities. For your nearest representative call 1 800-835-5182 or see the Worldwide Directory on our web site.

CORPORATE HEADQUARTERS/
 AIRCRAFT CONTROLS
 Rockford, IL, U.S.A.
 1 815-877-7441

This document is distributed for informational purposes only. It is not to be construed as creating or becoming part of any Woodward Governor Company contractual or warranty obligation unless expressly stated in a written sales contract.

© Woodward Governor Company, 1992
 All Rights Reserved

OUTLINE DRAWING

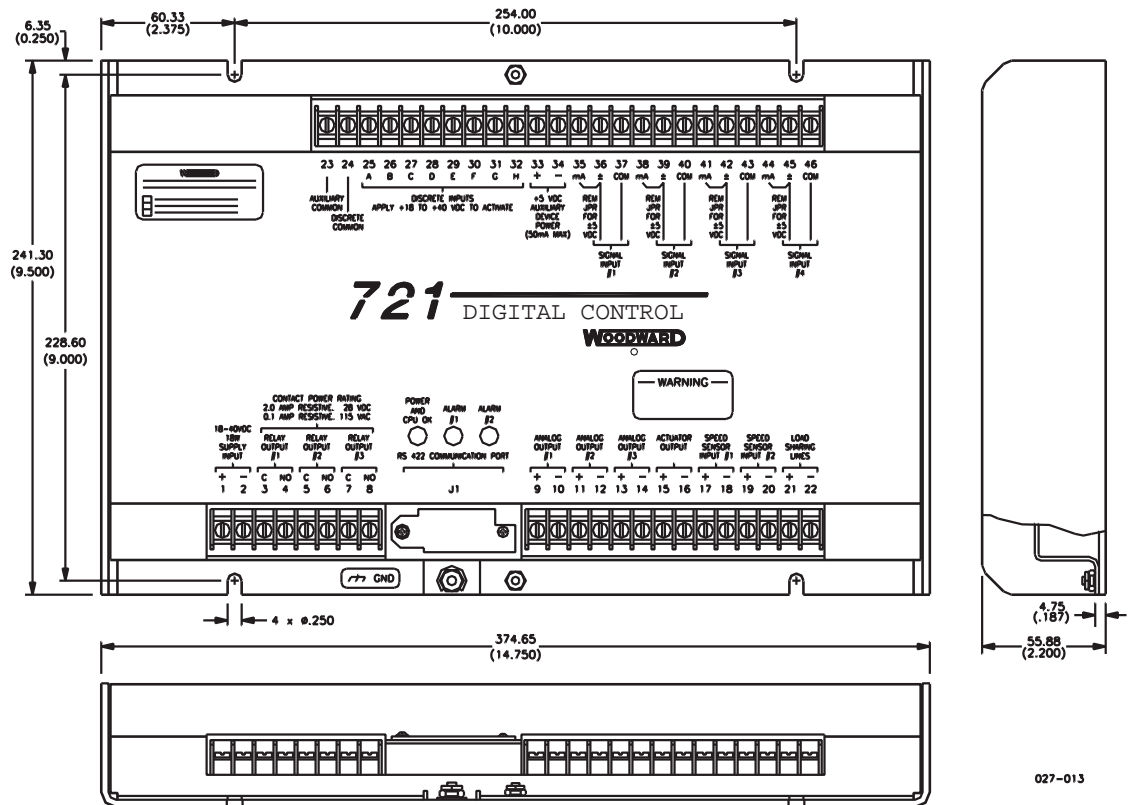

DECLARATION OF INCORPORATION

In accordance with the EMC Directive 89/336/EEC and its amendments, this controlling device, manufactured by Woodward Governor Company, is applied solely as a component to be incorporated into an engine prime mover system. Woodward Governor Company declares that this controlling device complies with requirements of EN50081-2 and EN50082-2 when put into service per the installation and operating instructions outlined in the product manual.

NOTICE: This controlling device is intended to be put into service only upon incorporation into an engine prime mover system that itself has met the requirements of the above Directive and bears the CE mark.

For more information contact: